

Technical Information

CK1368 CK1369

PRINTER-TYPE
CATHODE RAY TUBES

The CK1368 and CK1369 are 10" Printer-Type Cathode Ray tubes that can deposit an electrostatic charge on paper. The major application is in high speed printing equipment.

They employ a high-resolution, high-current gun. The small wire size, together with the thinness of the element, contribute to the excellent printing quality. Equipment designs using these types are capable of printing many thousands of characters per second.

GENERAL DATA

PRINTING ELEMENT CHARACTERISTICS:

CK1368 (single row)

Effective length—8 5/8"

Number of wires per inch—250

Thickness of element—.040"

CK1369 (multi-row)

Effective length—8 5/8"

Number of wires per inch—250

Thickness of element—.040"

Number of rows—40

Spacing of wire centers between rows—.004"

Phosphor (see application note 1) P1

Fluorescence Green

Persistence Medium

Focusing Method Magnetic

Deflecting Method Magnetic

Deflection Angle 40°

ELECTRICAL DATA

DIRECT INTERELECTRODE CAPACITANCES: (approx.)

Grid #1 to all other electrodes 8 μf

Cathode to all other electrodes 5 μf

DESIGN MAXIMUM RATINGS:

Peak Heater-Cathode Voltage: Max. \blacklozenge

Heater Negative with Respect to Cathode 180 volts DC

Heater Positive with Respect to Cathode 180 volts DC

Anode Voltage \blacktriangle 25,000 volts DC

Grid #2 Voltage 700 volts DC

Grid #1 Voltage

Negative—Bias Value 180 volts DC

Positive—Bias Value 0 volts DC

Positive—Peak Value 0 volts DC

CHARACTERISTICS AND TYPICAL OPERATION:

Heater Voltage 6.3 volts \pm 10%

Heater Current 0.6 amps.

Collector Voltage \blacktriangle 20,000 volts DC

Grid #2 Voltage 450 volts DC

Grid #1 Voltage \oplus -60 to -115 volts DC

MECHANICAL DATA

BASE Small Shell Duodecal
7 Pin

CAP Small Cavity (J1-21)

MOUNTING POSITION Any

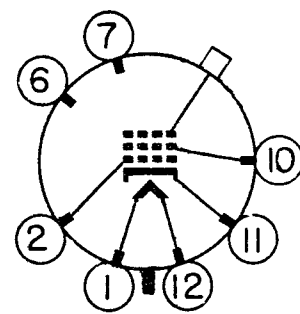

BOTTOM VIEW

TERMINAL CONNECTIONS:

Pin 1 Heater

Pin 2 Grid #1

Pin 6 NC

Pin 7 NC

Pin 10 Grid #2

Pin 11 Cathode

Pin 12 Heater

Cap Anode (Collector)



CK1368 CK1369

PRINTER-TYPE CATHODE RAY TUBES

ELECTRICAL DATA (Cont'd.)

CHARACTERISTICS AND TYPICAL OPERATION: (Cont'd)

Focusing Coil Current ■	717 ampere turns
Spot Position (undeflected) □	1/2 inch radius

MAXIMUM CIRCUIT VALUES:

Grid #1 Circuit Resistance	1.5 meg. max.
----------------------------	---------------

- ▲ *At or near this rating, the effective resistance of the collector supply should be adequate to limit the anode input power to 6 watts.*
- ◆ *Cathode should be returned to one side or to the mid-tap of the heater transformer winding.*
- ⊕ *Visual extinction of focused undeflected spot.*
- *The center of the undeflected focused spot will fall within a circle of 1/2 inch radius concentric with the center of the tube face, with tube shield.*
- *For Standard Focus Coil #106 or equivalent, positioned with air gap toward faceplate and center line of air gap 14" from reference line and collector current of 200 microamperes, the current will be approximately 160 Ma.*

PRINCIPLES OF OPERATION:

The printing element is made of fine wires imbedded in glass that permit electrons from the cathode ray beam to pass through the wires to the outside surface. Deflection and amplitude modulation of the electron beam striking the printing wires causes electron charges to be established on paper which acts as a dielectric. As the paper moves across the printing-element face plate, the electron charges actually form the characters that are desired. The characters can be made visible by developing the paper in a positively charged ink and fixing. Since the electron charge on the paper is proportional to the cathode ray beam current, it should be possible to obtain half tones.

APPLICATION NOTES:

1. Proper focus and sweep-scan alignment are accomplished by observing the electron beam as it strikes the phosphor. Side-viewing windows are provided for this purpose. The phosphor is on an area adjacent to the printing element. After initial adjustments are made, the scanning beam is moved to the printing element and final adjustments are made by actual printing process tests.
2. The beam spot size at optimum focus is approximately .003" for beam currents up to 200 μ A. Nominal resolution is approximately 100 TV lines per inch.

These data identify a particular developmental tube design and the type designation or the descriptive data may be subject to change or abandonment.



CK1368
CK1369

PRINTER-TYPE CATHODE RAY TUBES

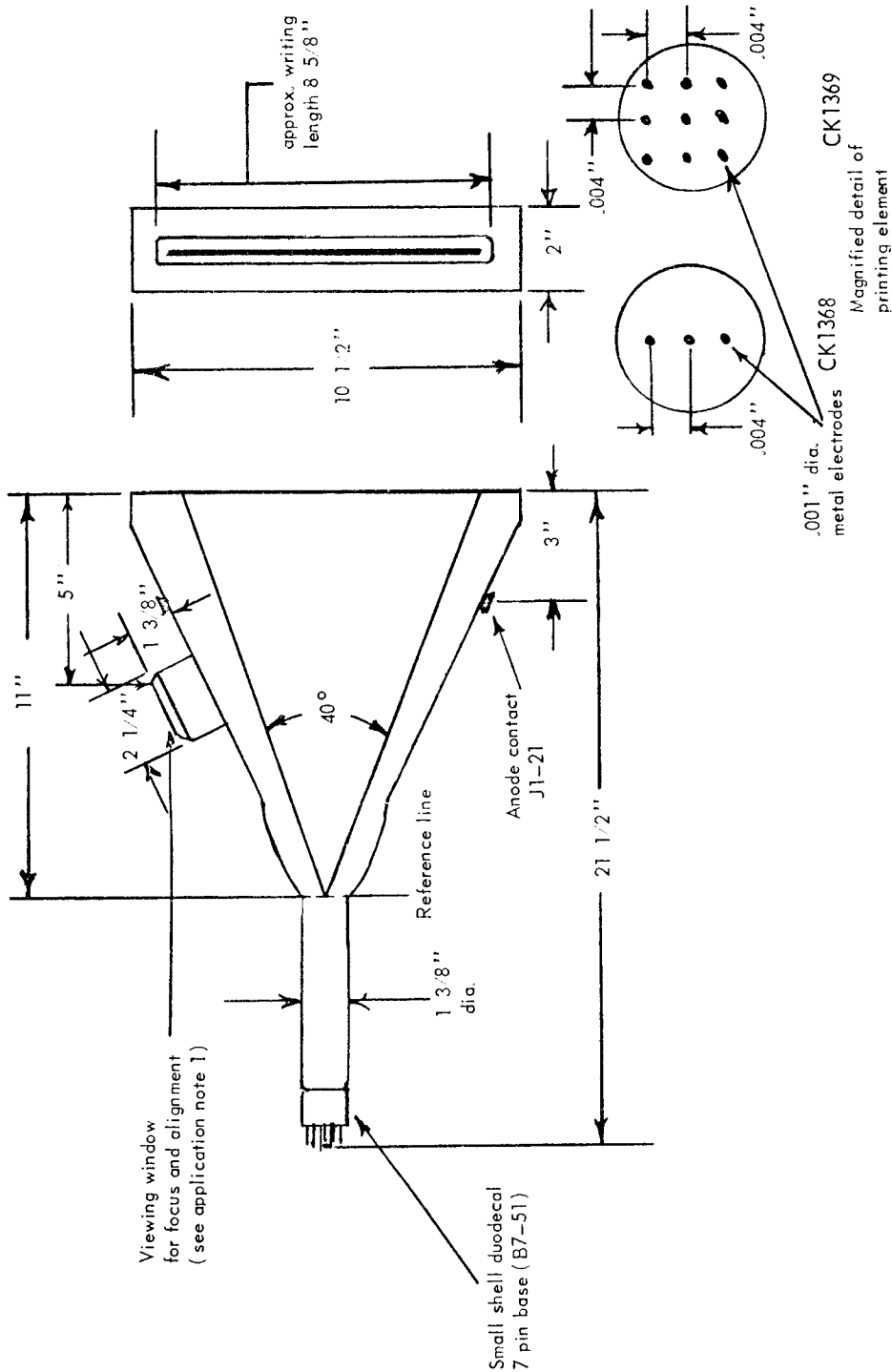

* All dimensions are approximate and there may be variations in samples supplied.